



		Transverse axis	Vertical axis	Extraction axis	SCP2 control panel
Working stroke	mm	3000	2000	1200	Storage for 100 programs with 300 program lines
Top speed	m/s	3	1.8	1	Standard palletizing program
Application on injection moulding machines	tonnes	800-1500			Immediate switching between 2 languages, multiple language available
Positioning reproducibility		± 0.2			User definable safe working areas (8 in total)
Manipulable weight	(kg) *	30			Program backup/restore via USB
Pickup device turning	(C axis)	0° - 90°			Multiple passwords allow customized protection levels
Pickup device rotation	(A axis)	0°-90°/0°-180° (Optional)			Control monitors system conditions and maintenance status
Piece presence control with vacuum switch		standard			Expandable and removable Input and 12 Output modules
E.O.A.T control		standard			Controls up to 6 axis, with synchro movements
Compressed air supply	(bar) kPa	(6) 600			Remote assistance via ethernet available on request
Venturi vacuum system max. air consumption	(NI/min)	24			Runs up to 10 parallel programs
Mains voltage		3x400-480 VAC TT TN system			Easy positioning teaching
Maximum rated power	(kW)	4			
Auxiliary control voltage	(V d.c.)	24			
Noise level	dB(A)	<85			
Paintwork		RAL 7016 - RAL 9022			
Electrical panel paintwork		RAL 7035			
Interfacing		Euromap 67 - 12 (optional)			
Weight of manipulator	(kg)	635			
Weight of electrical panel	(kg)	98			

\* Including pickup device and depending on application, speeds and accelerations

Technical data are not binding and are subject to modification without notice

# S20-S

**SYTRAMA**

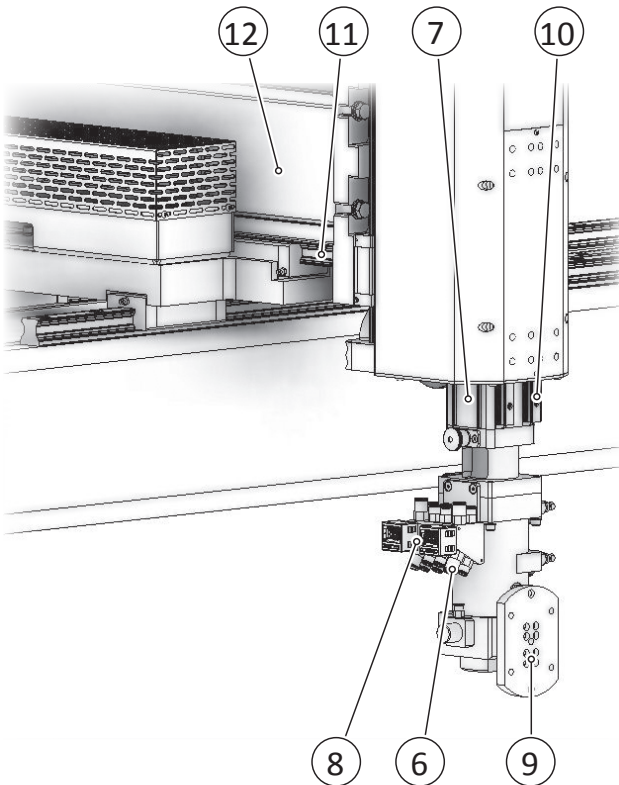
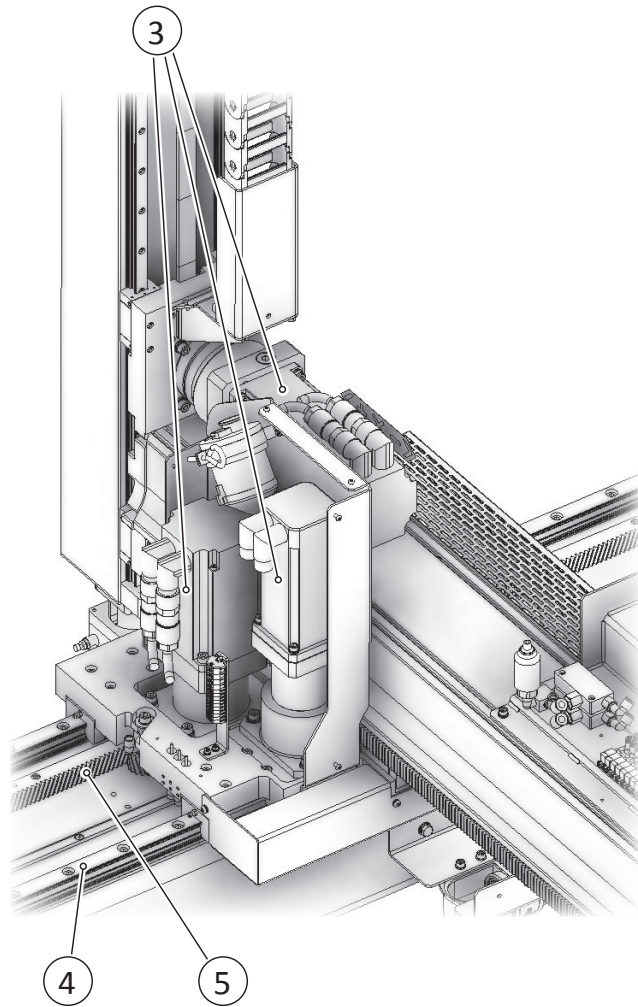
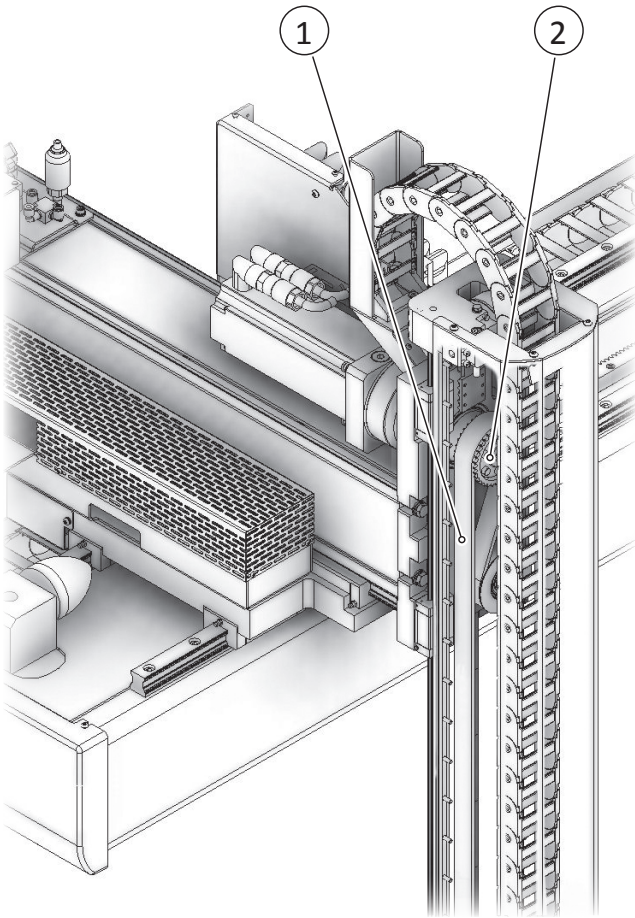

1. *Y axis high power belt*
2. *low maintenance and accurate belt transmission*
3. *brushless motor*
4. *Z axis high-precision guiding system with sliding block on prismatic guides*
5. *Z axis rack*
6. *easy connection for pneumatic utility*
7. *special aluminum designed for high stiffness*
8. *analogic measuring vacuum, programmable from keyboard*
9. *90° pneumatic overturning*
10. *Y axis high-precision guiding system with sliding block on prismatic guides*
11. *X axis high-precision guiding system with sliding block on prismatic guides*
12. *special aluminum designed for high stiffness*